

BIOLOGICAL SAFETY CABINET (NB-602WS/NB-602WSL)

The primary purpose is to serve as the primary means to protect the laboratory worker and the surrounding environment from pathogens. All exhaust air is HEPA-filtered as it exits the bio safety cabinet, removing harmful bacteria and viruses.

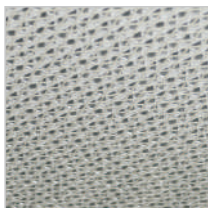

Filter
Filter built in work station is used by two sort of it. One of the filters, called PRE Filter is located at air intake removes dust, The other filter, called HEPA is high profile to remove over 99.99% particle (0.3micron) over 99.99%.

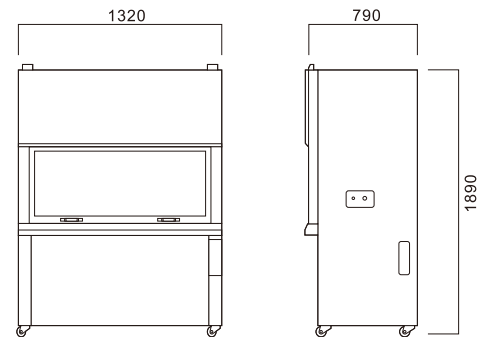
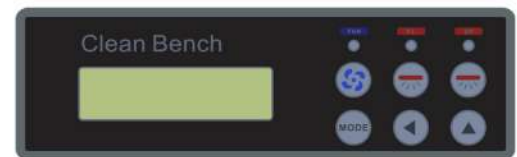

Working Table
Working table is manufactured by SU304 H.L in order to be doing well sterilization and cleaning but also Stopper installed at bottom helps work-station keep level and fixed during working. For using microprocessor, totally no vibration type work station is possible to be manufactured by separating table from the instrument.

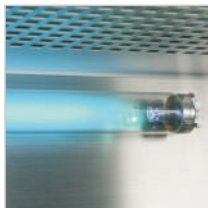

U.V Lamp
Two U.V Lamp are installed in Clean Bench, which sterilize a germ in the air and protect against contamination inside work station. 1set of Lamp is located at above filter to sterilize a germ in the air and the other set of Lamp is located at upper side in chamber to sterilize whole chamber.



Pressure Gauge
By checking the pressure gauge which indicates internal air pressure, it allows you to notice the filter defects as well as the timing of replacing the filter.



Low Noise Blower
Clean Bench should be low noise and vibration but also required to uniform wind velocity. Design with high efficiency Blower and double dustproof structure ensure efficient performance and no noise.

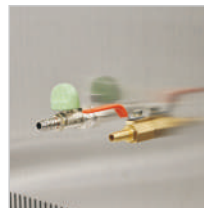

Gas Valve, Vacuum Cock

Optional Outlet
Convenient using with equipped with 110V/220V wall socket



Features

- High efficiency HEPA filters.(Main filter, Pre-filter)
- LCD information display for filter life remaining program in numeral.
- UV lamp minimizes contamination of work-environment, of viruses in the air.
- Low noise, high efficiency blower motor circulate air in cabinet.
- Smart software can allow to manage 9 step of wind speed control.

Air Flow Diagram(※ Except Standard Air flow type(Bio Hazard Safety), please contact us for other type air flow.)

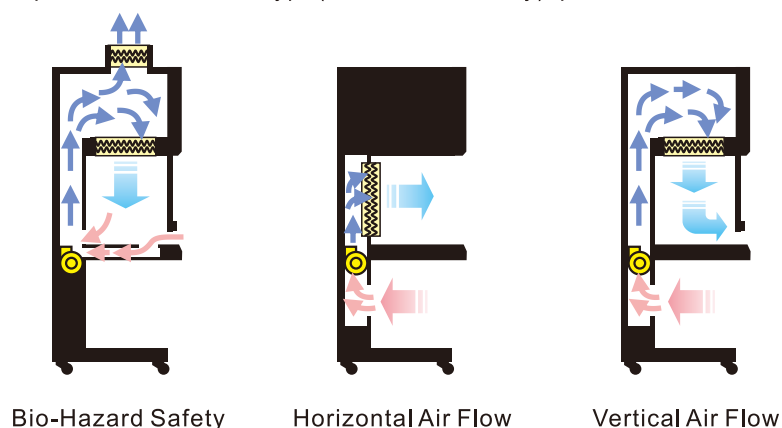

Specification



Items	Unit	NB-602WS	NB-602WSL
Chamber dimensions	mm	840(W)x600(D)x710(H)mm	1200(W)x600(D)x710(H)mm
Overall dimensions	mm	960(W)x790(D)x1920(H)mm	1320(W)x790(D)x1920(H)mm
Illumination	W	F,L 20Wx2ea	F,L 30Wx2ea
Sterilization	W	U.V 20Wx2ea	U.V 30Wx2ea
Blower	HP	1/4HP	1/3HP
Main filter		HEPA Filter(0.3 μ m 99.99%)	HEPA Filter(0.3 μ m 99.99%)
Pre filter		Nylon Filter	Nylon Filter
Exhaust filter		HEPA Filter(0.3 μ m 99.99%)	HEPA Filter(0.3 μ m 99.99%)
Clean liness		Class 100	Class 100
Wind velocity		0.3~0.45m/sec	0.3~0.45m/sec
Flow rate		Exhaust 30%, Recirculation 70%	Exhaust 30%, Recirculation 70%
Door type		Balance weight type	Balance weight type
Material			
inner		Stainless steel(SUS304)	Stainless steel(SUS304)
outer		SCP-1 with Powder coating	SCP-1 with Powder coating
door		Sliding Door Tempered Glass	Sliding Door Tempered Glass
Noise	db	Less Than 65	Less Than 65
Utility		Electric outlet, Gas Cock, Vaccum Cock	Electric outlet, Gas Cock, Vaccum Cock
Power	V,Hz	110/220V, 50/60Hz	110/220V, 50/60Hz
	W	400W	500W